

The Analysis of Sound. Part I. The Experimental Analysis of Sound in Air and Water: Some Experiments towards a Sound Spectrum. Part II. The Theory of Analysis of an Electric Current by Periodic Interruption

Guy Barlow, H. B. Keene and G. Barlow

Phil. Trans. R. Soc. Lond. A 1922 **222**, 131-166

doi: 10.1098/rsta.1922.0005

Email alerting service

Receive free email alerts when new articles cite this article - sign up in the box at the top right-hand corner of the article or click [here](#)

To subscribe to *Phil. Trans. R. Soc. Lond. A* go to: <http://rsta.royalsocietypublishing.org/subscriptions>

*The Analysis of Sound.**

PART I.—*The Experimental Analysis of Sound in Air and Water : Some Experiments towards a Sound Spectrum.* By GUY BARLOW, D.Sc. (Wales, Lond., Birm.), F.Inst.P., Lecturer in Physics in the University of Birmingham, and H. B. KEENE, D.Sc. (Birm.), F.Inst.P., Lecturer in Physics in the University of Birmingham.

PART II.—*The Theory of Analysis of an Electric Current by Periodic Interruption.* By G. BARLOW, D.Sc.

Communicated by SIR OLIVER LODGE, F.R.S.

Received April 6,—Read June 23, 1921.

PART I.—THE EXPERIMENTAL ANALYSIS OF SOUND IN AIR AND WATER :
SOME EXPERIMENTS TOWARDS A SOUND SPECTRUM.

CONTENTS.

	Page
INTRODUCTION	132
APPARATUS	135
ANALYSIS OF A CURRENT	137
(1) <i>Simple Harmonic Current</i>	137
(2) <i>Close Pair of Simple Harmonic Currents—Resolving Power</i>	139
(3) <i>Current Containing Harmonic Series</i>	139
(4) <i>Complex Current</i>	140
ANALYSIS OF SOUND IN AIR	142
(a) <i>Magnetophone Receiver</i>	142
(1) Bowed fork, (2) Voice, (3) Organ Pipe, (4) Struck Fork, (5) Diaphragms, (6) Resonators	142
(b) <i>Carbon Microphone Receiver</i>	143
(1) <i>Pure Tones</i>	143
(2) <i>Note from Harmonical</i>	144
(3) <i>Complex Sound</i>	145
(4) <i>“ Background ” Experiments</i>	146

* The experiments described in this paper are published with the permission of the Admiralty. They form part of an investigation carried out by the authors in the Physics Department of the University of Birmingham during the years 1916 and 1917, at the suggestion of Sir O. LODGE on behalf of the Board of Invention and Research.

	Page
ANALYSIS OF SOUND IN WATER	146
(a) Sources of Sound	146
(1) Cylindrical Sounder	146
(2) Double Diaphragm Sounder	147
(3) Single Diaphragm Sounder	148
(4) Evinrude Row-boat Motor	149
(b) Receivers	149
(1) Metal Diaphragm Receiver	149
(2) Rubber Diaphragm Receiver with Adjustable Natural Frequency. Listening Arrangements	150
(c) Reservoir Experiments with Sounders	151
Natural Frequency of Sounders and Receivers	151
Metal Diaphragm Receiver—variation of amplitude with distance and depth	152
Rubber Diaphragm Receiver—disturbances—resonance—variation of amplitude with distance	153
(d) Sound Spectrum of Evinrude Motor (Reservoir Experiments)	154
Variation of Spectrum with Motor Speed	155
Variation of Spectrum with Direction	156
Variation of Spectrum with Depth	156
Variation of Amplitude with Distance	156
Analysis by Telephone	158

INTRODUCTION.

A METHOD of analysing an alternating current termed "Analysis by Periodic Interruption" was worked out by G. BARLOW in May, 1916, and is described by him in some detail in Part II. The present paper, Part I., gives an account of certain experiments in which this method has been applied to the analysis of sound vibrations in air and water with the object of obtaining "sound spectra." The principle of the method may be stated as follows. The alternating current circuit contains a direct current galvanometer and also an interrupter of which the speed can be varied over the whole range of frequency to be investigated. Generally the type of interrupter used is such

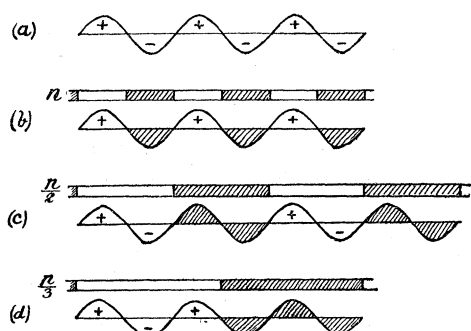

Fig. 1. Interruption of a simple harmonic current at frequencies n , $n/2$, $n/3$.

that the intervals during which the circuit is open and closed are equal. When the interruptions synchronize with any component $A \sin 2\pi nt$ of the current, fig. 1 (a), the galvanometer responds by giving a steady deflection of magnitude depending on the phase difference. Fig. 1 (b) shows interruptions and current in the same phase. Practically it is better to allow a slight difference in frequency; the galvanometer then oscillates slowly to and fro as the phase alters. The maximum amplitude of the galvanometer swings is then proportional to the amplitude A of the component current—actually

it measures A/π . In making the analysis the frequency of interruption is slowly increased over the whole range. The approach to the condition of synchronism is indicated by

a rapid oscillation of small amplitude followed by slower oscillations of greater amplitude until the maximum is reached. Afterwards the oscillations die down in the reverse order. This characteristic motion exhibited by the galvanometer will be referred to by the term "response." In this way the amplitude of each component may be determined. At the same time the corresponding frequency is obtained by observing, at the moment of maximum, the frequency at which the interrupter is driven. For a component of given amplitude the range of frequency over which the response is greater than half its maximum value, and which may be called the "width of response," is the *same* at all frequencies. For example, if a response at 10/sec. falls to half value for frequencies of interruption of 9 and 11/sec., then one at 1000/sec. will fall to half value at 999 and 1001/sec. It will therefore be seen that it is necessary to have perfect control over the speed of interruption, especially in the higher frequency region, and the same time must be spent in sweeping over a range such as 1000–1100/sec. as over 10–110/sec. In measuring a response the rate at which the speed of interruption may be changed is conditioned by the period of the galvanometer. It is necessary that the speed should not change sensibly during an interval of time of the order of the galvanometer period. The galvanometer may be of any type, but its vibrations should be well damped so as to be nearly dead-beat. A suitable period is 3 seconds. Under these conditions the width of response is 0.7/sec.

It is a peculiarity of this method of analysis that a *single* simple harmonic component of frequency, n , gives rise to responses not only when the frequency of interruption is n , but also when it is $\frac{1}{3}n$, $\frac{1}{5}n$, $\frac{1}{7}n$, &c., and these responses have amplitudes $\frac{1}{3}$, $\frac{1}{5}$, $\frac{1}{7}$ of the fundamental response. These responses will be called "Subharmonics." Their origin is made clear in fig. 1, which also shows why the even-order subharmonics $\frac{1}{2}n$, $\frac{1}{4}n$, $\frac{1}{6}n$, &c., are non-existent. When the alternating current represented by (a) is interrupted at its frequency n , all the negative elements are suppressed as shown in (b), giving a unidirectional current in the galvanometer. When interrupted at $\frac{1}{2}n$, as in (c), an equal number of positive and negative elements are passed through giving no resultant current in the galvanometer. But when interrupted at $\frac{1}{3}n$ as represented in (d), there is a resultant current due to the odd positive elements. This is the third order subharmonic, and it will be seen by comparing (b) and (d) that it has one-third the magnitude of the fundamental.

The presence of these subharmonics is not so objectionable in practice as one might expect, in fact their frequencies and relative magnitudes have on certain occasions assisted in the identification of the fundamental with which they are associated. There is a close analogy with grating spectra, inasmuch as each subharmonic corresponds to a spectrum of a different order. The even orders are absent just as in a grating where the opaque and transparent parts of the grating-element are equal in width. If the intervals of make and break are unequal, then the even-order subharmonics are introduced.

A type of interrupter has been constructed in which by repeating the sequence of

intervals shown in fig. 2 it has been found possible to eliminate the subharmonics $\frac{1}{3}n$, $\frac{1}{5}n$, $\frac{1}{15}n$, &c., in addition to the even orders. The fundamental response is reduced to three-fourths of its usual value, and there are certain other disadvantages suggested by the few experiments

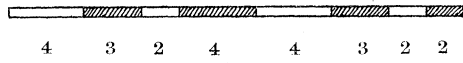

Fig. 2.

which have so far been made.

In order to analyse by this method of periodic interruption mechanical vibration of a solid body or of sound waves in air or water, the vibration must be converted into an electrical current which in wave-form faithfully represents the original motion. Some distortion of the wave-form would not be a serious objection, provided it followed a simple relation allowing correction to be made. Actually very few methods of converting vibration into current are available, and none of these is free from objection. Among the most practicable are:—

- (1) Variation of electrical resistance by pressure, *e.g.* carbon microphone.
- (2) Variation of electrical resistance by change in thermal conditions, *e.g.* Tucker Hot Wire Microphone.
- (3) Electromotive force generated by induction, magnetophones, &c.

It may be pointed out that all these methods depend on induction (assuming a transformer is used in (1) and (2)), and the final current therefore represents the *velocity* of the vibration under investigation, but this is not an objection from the point of view of analysis.

For, suppose the original vibration is resolved into simple harmonic components—

$$a_1 \sin (2\pi n_1 t + \alpha_1) + a_2 \sin (2\pi n_2 t + \alpha_2) + \&c. ;$$

then, assuming no other form of distortion, the current will be proportional to

$$2\pi a_1 n_1 \cos (2\pi n_1 t + \alpha_1) + 2\pi a_2 n_2 \cos (2\pi n_2 t + \alpha_2) + \&c.$$

The analysis of this current will then give correctly the frequencies of all the component vibrations, but in each case the amplitude is magnified in proportion to the corresponding frequency. The product $2\pi a n$, representing the maximum velocity, is itself an appropriate measure of the importance of the component, as the relative energies for different components are proportional to $(an)^2$.

In the present experiments the determination of the frequencies of the components has been effected with all the accuracy desired, but as it has not yet been found possible to avoid selective action due to resonance of diaphragms, the amplitudes of the components are not faithfully represented. No attempt has been made to deduce the absolute amplitudes of motion of the original vibration.

When the components of a vibration have strictly commensurable frequencies, as in a harmonic series, the phase relations of the components are quite definite, and the determination of the relative phases might be of value—in fact it would be necessary

if it were required to reconstruct the wave-form of the vibration. It would not be difficult to adapt the method of analysis by interruption for the determination of phase-difference, but no experiments in this direction have yet been made. Hence at present the method is incomplete in that it fails to take account of wave-form. If the wave-form were required it would appear simpler to deal with it directly by means of an oscillograph method than to build it up from a complete analysis.

APPARATUS.

The interrupter (fig. 3) consisted of a brass cylinder made up of five discs; the first was complete and served as a slip-ring, the other four contained ebonite segments giving respectively 1, 4, 16 and 64 interruptions per revolution of the cylinder. Contact was made by means of two small brushes cut from $\frac{1}{20}$ mm. sheet brass, each brush possessing four or five separate fingers. One brush pressed lightly on the slip-ring, the other on whichever disc was the most convenient for the frequency under examination. The electric contact was found to be satisfactory when the surfaces were kept clean and well lubricated with machine-oil. The cylinder, insulated with ebonite, was mounted directly on the shaft of an electric motor the

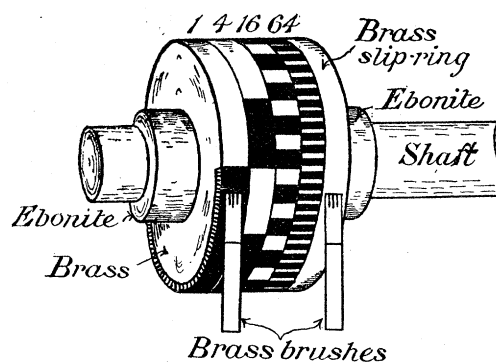

Fig. 3. Interrupter.

speed of which could be regulated over the range 3–30 revs./sec. The four discs gave overlapping ranges of interruption frequencies with a total range of 3 to over 2000/sec.

It was required that the rotation of the interrupter should be extremely uniform and perfectly under control. This is especially important for analysis at high frequencies; thus for 1000/sec. an irregularity of rotation of 1 in 2000 would in one second completely reverse the phase of the response, and with a galvanometer of 3 sec. period the full value of the response would not be obtained.

Much preliminary work was done in examining the conditions necessary for steadiness and smooth running of small motors. Two forms of apparatus have been constructed:—

(1) A Siemens-Schückert 12-volt $\frac{1}{16}$ h.p. motor was directly coupled to a flywheel (radius 11 cm., mass $7\frac{1}{2}$ kgm.) to prevent sudden changes of speed. This apparatus, which was used in nearly all the laboratory experiments, was suitable for exact measurements, as the motor could be made to run very slowly over any required small range of speed, and this range could be repeated by using the finger as a brake on the flywheel. Since plain lined bearings were used, there was the disadvantage that the ultimate speed attained was limited only by the work done in friction, and this varied with the state of the lubrication. The great weight of the flywheel made this frictional

work so considerable compared with the power of the motor that it was not feasible to use an eddy-current brake to give further stability.

(2) This apparatus (fig. 4) was made as light as possible so as to be easily portable.

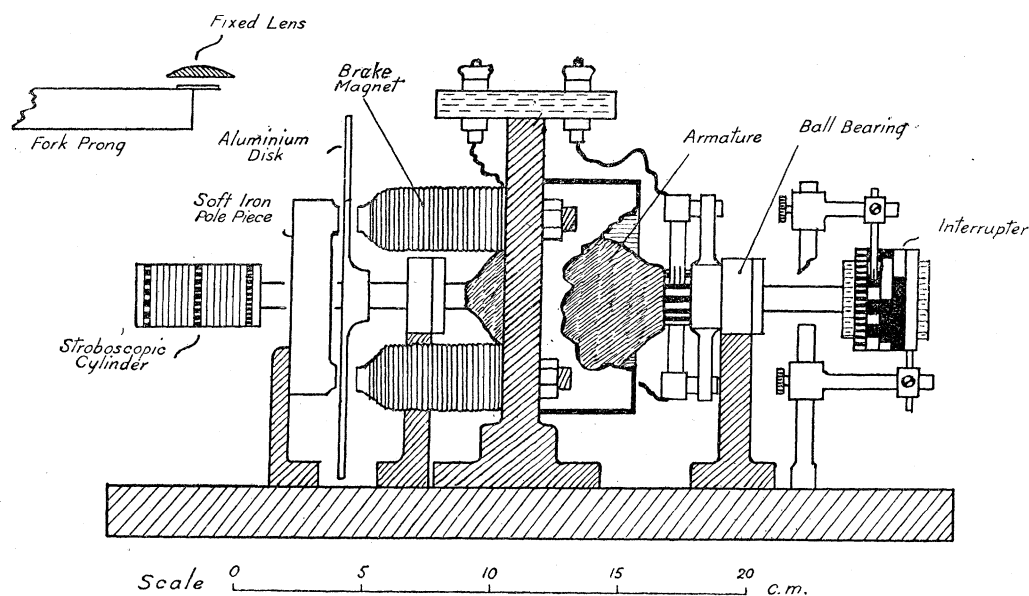

Fig. 4. Portable motor-driven interrupter (elevation).

The shaft of a Siemens-Schückert 12-volt, $\frac{1}{40}$ h.p. motor was lengthened and fitted with a couple of ball-bearings carried by brackets from a rigid base-plate. No fly-wheel was used, the required steadiness being given by an eddy-current brake consisting of an aluminium disc (radius = 7 cm.) attached to the shaft and spinning between the four poles (distant $5\frac{1}{2}$ cm. from the axis) of an electromagnet excited by a constant current. In this case the friction of the bearings only formed a small fraction of the total work done.

The different circuits were excited as follows:—

Armature	6 volts, 0-3 amperes.
Field	6 „ 3 „
Brake	2 „ 1 ampere.

Except in special cases the whole range of frequency could be covered by variation of the armature current alone.

In addition to portability (the total weight was 8 kgm.) this apparatus possessed, on account of its small inertia, the advantage of extreme rapidity in attaining a steady speed. For a given adjustment the final speed was reached in about 3 seconds from rest, whereas the former apparatus required 10 minutes.

The chief source of trouble in obtaining a constant speed was found to be due to irregular variations in brush-contact on the commutator of the motor. Both carbon and solid copper brushes were found to be unsatisfactory on this account. These were

eventually replaced by springy brushes built up of long thin strips of phosphor-bronze, each strip being slit longitudinally into alternately two and three fingers. In this way a number of independent contacts was obtained, and much steadier conditions of running of the motor were secured. Even with the improved brush design occasional irregularities in speed still occur, and are usually traceable to the contact conditions on the commutator. This appears to be the outstanding difficulty in obtaining a constant speed of revolution with an electric motor.

The speed of the motor was measured by a stroboscopic method.* For this purpose the shaft carries a cylinder the surface of which is divided into 21 rings. Each ring is marked out into 20, 21, 22 . . . 41 equally spaced black squares with white intervals, and for ease in identification every fifth ring is tinted red. The stroboscopic cylinder is viewed through double slits mounted on the prongs of a maintained fork (64/sec.) giving 128 views per second of the rotating patterns. The speed is determined by observing the number of the ring which appears to be stationary. When, as is generally the case, no ring is exactly stationary, then two consecutive rings are seen to rotate slowly in opposite directions with different speeds. By measuring the rate of progression of one of these the required frequency may be obtained with a degree of accuracy limited only by the constancy of the motor speed. In practice it is sufficient to interpolate by estimation, as this can be done without giving an error in the frequency of more than $\frac{1}{3}$ per cent.

The laboratory experiments were made with a Broca galvanometer (10 ohms), and, when required, a transformer having a primary resistance of 4 ohms and secondary of 90 ohms. At the reservoir a Broca galvanometer (100 ohms) was used, and also a transformer with resistances 60 and 110 ohms. The period of the galvanometer was in both cases adjusted to be 3 sec., and then made almost dead-beat. For the purpose of dealing with vibrations of great complexity, it would appear quite practicable to modify the present apparatus to give a photographic record of the "spectrum."

ANALYSIS OF A CURRENT.

Before proceeding to analyse sound vibrations the following experiments were made to test the reliability of the method by applying it to analyse alternating currents of known characteristics.

(1) *Simple Harmonic Current.*

The current was generated in a small coil, wound in the form of a figure 8, by the motion through it of a U-shaped magnet (made from a piece of knitting-needle 4 cm. long) attached either to the prong of an electrically maintained fork, or in the case of the lower frequencies to an electrically maintained steel strip.

* RAYLEIGH, 'Phil. Mag.,' 1907.

The amplitude of the current i_0 in c.g.s. units was calculated from the formula

$$i_0 = \frac{JN \cdot 2\pi na}{\sqrt{R^2 + 4\pi^2 n^2 L^2}},$$

where,

J = magnetic flux cut by one turn of the coil per cm. displacement, directly determined by means of a ballistic galvanometer.

N = number of turns on the coil, usually 1–10 turns.

n = frequency.

a = amplitude of motion of the magnet, determined by a microscope with eyepiece scale.

R = resistance of the circuit (9 ohms) in c.g.s. units.

L = self-induction of the circuit. The only appreciable self-induction was due to the Broca galvanometer ($\cdot 0073$ henry).

On interruption the current measured by the galvanometer response is i_0/π , and from the known sensitiveness of the galvanometer (35 div. per microampere) the magnitude of the response can be calculated and compared with the observed value.

The results for experiments made with frequencies ranging from 1–2000/sec. are given in the following table:—

Frequency. n .	Amplitude of motion. a .	Amplitude of current, i_0 .	Galvanometer deflection (observed).	Galvanometer deflection (calculated).
	cm.	amp.		
1·07	0·200	$0\cdot67 \times 10^{-6}$	70*	73
6·4	0·170	3·4	35	38
11·5	0·210	3·1	38	34
14·9	0·200	3·8	47	43
27·5	0·210	7·4	70	83
95	0·200	11·0	120	120
500	0·025	14·3	190	160
990	0·002	1·26	20	14
2040	0·003	3·8	42	40

The experimental error is likely to be greatest in the case of the two highest frequencies owing to the small amplitudes to be measured. Moreover, the 2040 fork had to be sustained by bowing. The agreement between the observed and calculated values for all frequencies is as good as can be expected, but it only holds if account is taken of self-induction, since at the higher frequencies the correction for impedance is very large.

* Galvanometer with 9·4 sec. period, giving 340 div. per microampere.

The currents were very nearly pure, but contained traces of the even harmonics. Thus the analysis for the 95 fork gave the current-amplitudes of the components n , $2n$, $4n$, in the ratio $1 : \frac{1}{21} : \frac{1}{60}$. These harmonics may have been present in the fork vibration, but it is more likely that they were produced by want of uniformity in the magnetic flux of the U-magnet. The so-called subharmonic responses described above were also observed.

(2) *Close Pair of Simple Harmonic Components—Resolving-Power.*

The current was produced by putting in series two U-magnet generators on separate forks of frequency 64/sec., which could be adjusted to have a slight difference of frequency by means of sliding loads on one of them. The responses were examined for each alone, and then for both together. When the difference in frequency was reduced to 0.6/sec. the two components could still be resolved, owing to a distinct drop between the two maxima. Separation was also effected when the components were very unequal in magnitude, *e.g.* a ratio 5 : 1. In all cases the double nature of the response was at once evident from the characteristic beating of the galvanometer oscillations, whereby it was readily distinguished from that due to a single frequency. When the components are unequal the beating is more distinct on the side of the smaller. The difference in frequency of the components can be determined directly by the frequency of the beats without observing the positions of the two maxima.

Experiments on resolving-power were not made at higher frequencies, but theory shows that two components with the above limit of frequency-difference should be resolved whatever their absolute values, *e.g.* 1000 and 1000.6/sec.

(3) *Current Containing Harmonic Series.*

Two types of current were produced simultaneously from the same electrically maintained fork with mercury contact, 32/sec.—the first by induction in a couple of turns of wire round the electromagnet of the fork, the second by using a small air-transformer consisting of a few turns of wire (giving negligible self-induction) in which the current in the primary was interrupted by a separate platinum contact attached to the fork-prong and dipping into mercury. The level of the mercury was adjusted to give equal time intervals of make and break. By means of a “throw-over” key the amplitude of corresponding harmonics in the two currents could be compared.

Harmonic.	Frequency.	Current-amplitude with iron-transformer.	Current-amplitude with air-transformer.
1	32	280	215
2	64	150	10 erratic
3	96	240	210
4	128	210	20 erratic
5	160	180	205
6	192	175	30 erratic
7	224	135	200
8	256	150	20 erratic
9	288	100	190
10	320	130	40 erratic
11	352	85	180
12	384	80	20 erratic
13	416	85	160
14	448	65	20 erratic
15	480	150	160
16	512	135	120 fairly good
17	544	140	170
18	576	140	140
19	608	115	145
20	640	120	130
21	672	110	100
22	704	120	120
23	736	95	100
24	768	100	80
25	800	90	130
29	928	85	90
32	1024	90	100
33	1056	70	100
35	1120	60	130
37	1184	70	130
40	1280	95	120
41	1312	80	110
48	1536	60	90
49	1568	50	60

After the twenty-fifth the examination of several harmonics was omitted. The table shows that the current produced by the air-transformer consists of practically odd harmonics only, until the higher frequencies are reached, and their amplitudes are nearly equal. This is what would be expected from the nature of the make and break.

(4) *Complex Current.*

In this experiment six maintained forks were used with their U-magnet generators in series. The current-amplitude and frequency were first measured for each generator taken separately, then all were excited and a complete analysis made. This "spectrum" is given in fig. 5. It will be seen that all six primary constituents were found, together with their various subharmonics, and also a weak octave of the fork A.

The frequencies and amplitudes of the primaries were as follows :—

	Frequency.	Amplitude (Galvanometer response).
A	23·9	90
B	64·6	42
C	69·4	62
D	98·8	68
E	219·5	55
F	502	130

These values are sensibly the same as were obtained in the separate examination except for some small differences in amplitude easily accounted for by unavoidable variations in the amplitudes of the forks during the experiment. As the whole range explored extended from 3–2000/sec. and every response found was critically examined, this analysis occupied a long time—about four hours.

In the diagram the response F is shown accompanied by companions F' and F'', forming a triplet. These companions are due to irregularities in the spacing of the segments of the 64 interrupter-disc. They are always given with this disc, but not with the others in which, presumably, the spacing is more uniform.

When two responses occur close together the amplitude of each is reinforced by the other. Several such examples occur in the diagram, notably in the case of A and C/3.

ANALYSIS OF SOUND IN AIR.

(a) *Magnetophone Receiver.*

A Graham's Patent "Loud-talking Apparatus" (iron diaphragm 10 cm. diameter, 0·061 cm. thick) was placed in series with the Broca galvanometer and interrupter. This instrument, although not extremely sensitive, proved to be satisfactory for analysing sounds. Examples of some of the experiments made are here briefly indicated :—

- (1) Bowed fork, $n = 512$, at 8 metres gave a good response at this frequency.
- (2) Voice, singing a note, $n = 256$, with moderate intensity gave a deflection off the scale.
- (3) Organ pipe, blown at a distance of a few feet. Analysis gave the fundamental $n = 531$ and also the third harmonic. The change to the octave on over-blowing was readily shown.
- (4) In determining the frequency of a fork it is not necessary that the vibration should be sustained. By tapping a 640 fork with a rubber hammer the frequency was determined by the interrupter to $\frac{1}{2}$ per cent.

- (5) In a similar way the fundamental frequencies were found for three metal diaphragms (3 in. diameter). The values obtained were 345, 890, 1520/sec.
- (6) Highly damped vibrations. The resonator box belonging to a standard 384 fork was tapped in front of the trumpet of the magnetophone. The maximum deflection was obtained at 344/sec., and the fork itself gave a response at 382/sec.

In those cases in which the vibrations are not sustained there is no regular response, but merely a kick on the galvanometer for each excitation. At any one speed the kicks may be of either sign, and they vary in magnitude over a certain range according to the phase-difference. The frequency is determined by the interrupter speed for which the range is a maximum, but, as would be expected, this maximum becomes ill-defined when the vibrations are highly damped.

In the above experiments electrically maintained forks were not used owing to their direct magnetic action on the magnetophone.

(b) *Carbon Granule Microphone Receiver.*

An ordinary commercial instrument (G.E. Co.) of the "solid-back" type with conical mouthpiece was suspended by thin rubber cords. Some preliminary experiments in which the receiver was enclosed in an exhausted vessel showed that no appreciable vibrations were communicated through the supports to the microphone when suspended in this way.

The electrical connections are shown in fig. 6. When required an additional resistance was placed in the galvanometer circuit to reduce the sensitiveness. As compared with the magnetophone the microphone has the following advantages:—

- (i.) Greater sensitiveness.
- (ii.) It is non-inductive, and therefore not affected by stray alternating fields from electric forks, &c.

The disadvantages are:—

- (i.) Resonance: The above receiver has a natural frequency about 1030/sec.
- (ii.) The *mean* resistance during vibration differs from the normal resistance (it is actually increased), and therefore the starting and stopping of a sustained sound gives kicks (in opposite directions) on the galvanometer.
- (iii.) The resistance, and consequently the sensitiveness, is therefore subject to uncontrollable variation.

(1) *Pure Tones.*—A fork 512, mounted on its resonator, when bowed or struck near the receiver gave, on analysis, deflections off the scale.

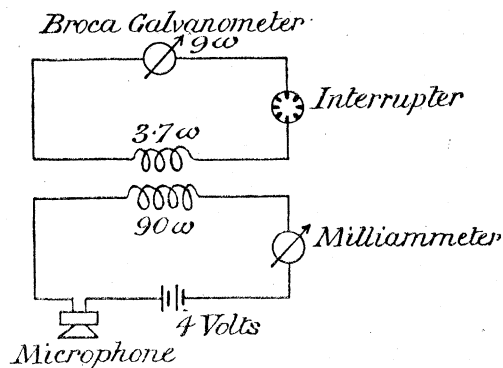

Fig. 6.

When bowed 8 metres away a response 150 div. was obtained. (The magneto-phone gave 20 div. under the same conditions.) When a 512 resonance box was placed in front of the microphone the response was increased to over 200 div.

Fork 2048 bowed at 2 metres gave 200 div.

It was noticed that the overtone of a certain pipe blown gently gave abnormal disturbances of the microphone without the interrupter. This disturbing frequency was found to be about 1030/sec. Starting and stopping a 1024 fork gave violent kicks on the galvanometer, indicating a large increase of microphone resistance during the vibration. This change of resistance was shown directly on the milliammeter in the microphone circuit. This effect suggested that the microphone would be abnormally sensitive to a note of about this frequency. This was actually the case; thus it was shown that the microphone as a detector was as sensitive as the ear for this particular frequency. *E.g.*, fork 1024 when bowed in adjoining room with doors shut was detected by the galvanometer; to the ear the note was only just audible.

Also this instrument was extremely sensitive to taps on a fork resonator-box, and also in a less degree to almost any sharp taps given by wooden objects—*e.g.*, putting down tool on table or walking about on wooden floor; locomotive whistles from the railway near by were especially effective.

(2) *Note from Harmonical* (ELLIS).—The note selected had a fundamental frequency of 66/sec. All harmonics up to the twentieth (the analysis was not carried further) were observed and their amplitudes measured. The results are given in the following table:—

Harmonic.	Frequency.	Response.	Harmonic.	Frequency.	Response.
1	66	100	11	726	70
2	132	100	12	792	10
3	198	50	13	858	15
4	264	40	14	924	5
5	330	60	15	990	80
6	396	20	16	1056	60
7	462	50	17	1122	60
8	528	14	18	1188	10
9	594	25	19	1254	5
10	660	50	20	1320	10

It will be seen that some of the harmonics are as important as the fundamental. The fifteenth, sixteenth and seventeenth harmonics are probably enhanced on account of their frequencies being nearly in resonance with the microphone. The subharmonics are not recorded in the table.

In illustration of the complexity arising from the subharmonics of strong harmonics, the following example from another experiment is given:—

The harmonical note 263/sec. contained a strong fourth harmonic of frequency $263 \times 4 = 1052$. This was greatly enhanced on account of its being so nearly in

resonance with the microphone. The subharmonic series of 1052 was in consequence pronounced. Thus in the experiment a marked response was observed at 151, which is $1052 \div 7$ nearly, *i.e.* the seventh subharmonic of the fourth harmonic of the fundamental vibration. In practice the presence of the subharmonics is generally of less inconvenience than this example might suggest, but it will be seen that analysis is particularly affected if the receiver possesses strong resonance-points very much *above* the region of frequency under analysis.

(3) *Complex Sound.*—In order to test the reliability of the analysis, it was thought desirable to produce a complex sound containing known constituents each of which could be examined separately. Four electrically maintained forks were placed on the same table, and grouped in front of the microphone receiver suspended on rubber cords independently of the table. The four forks selected had the following frequencies:—A 71·3, B 89, C 100, D 261/sec. With all forks sounding together a careful analysis was first made, in which each response was examined separately in order to determine accurately its magnitude and frequency. The result of this analysis is shown in fig. 7. It will be observed that the following frequencies were present:—

- (i.) The four fundamental vibrations A, B, C and D.
- (ii.) Weak octave of C. Those of A and B were not observed, while the octave of D was out of range.
- (iii.) All the important subharmonics of A, B, C and D, except in those cases where they were masked by other responses, *e.g.*, $\frac{1}{3}D$ was missed, as it was nearly coincident with the fundamental B.

With the exception of uncertain responses at 158 and 161/sec., all frequencies found in the analysis are accounted for. The frequency 161 may be due to a combination-tone, either $D - C = 161$, or $A + B = 160\cdot3$. A separate investigation showed that this response only occurred when the forks A and B were sounding together, and that it was not always present even under those conditions.

The analysis was now repeated by making a rapid sweep of the whole range by continuously increasing the speed of interruption *without stopping*

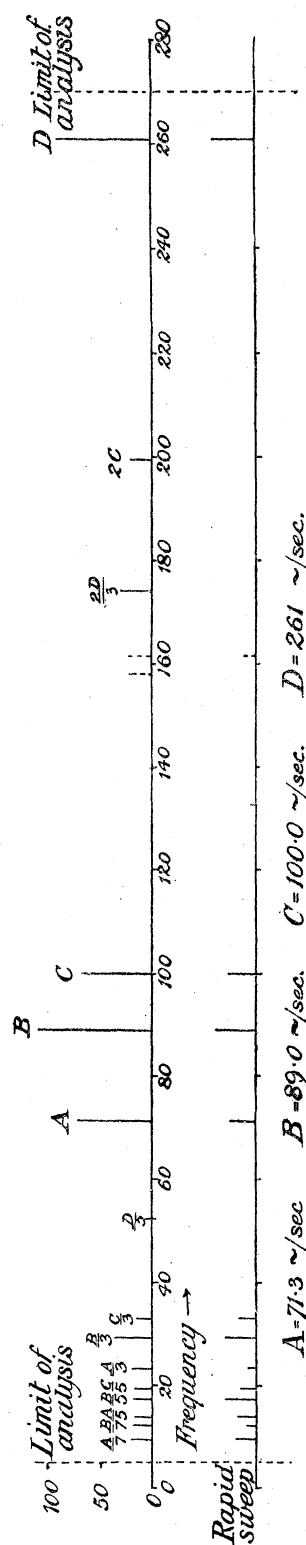

Fig. 7. Analysis of complex sound vibration. Range of analysis 5 ~/sec. to 270 ~/sec.

to examine the separate responses. The results of this sweep are given in fig. 7 where it will be seen that no important vibrations were missed, and that their frequencies were obtained with almost the same degree of accuracy as in the more careful analysis. As would be expected, the amplitudes as determined in this rapid sweep were generally less than before, and could only be determined roughly.

Other experiments which cannot be described here have shown that all responses, however small or irregular, which occur in an analysis can always be accounted for. In fact, analysis has sometimes indicated the presence in the source of quite unsuspected vibrations which have been afterwards shown to exist by other means.

Replacing the galvanometer by a telephone, a weak sound of machine-like quality was heard, the frequency $D = 261$ being most pronounced, and also a marked throbbing which was probably associated with the heating of B and C (89 and 100).

(4) *Analysis as affected by a General Background of Sound.*—The object of these experiments was to determine to what extent a definite vibration could be masked by the presence of a general “background” of sound. A suitable background was found to be produced by placing a roaring bunsen near the suspended microphone. As heard in the telephone this background completely masked the note from a 256 maintained fork, so that one could not detect when the fork started or stopped. On analysis it was found that the background alone gave a disturbance on the galvanometer at all frequencies of interruption, while the fork response was 15 times that due to the background, showing that in this case the analysis is vastly superior to the ear using the telephone. Similar experiments were made with a 512 fork, but it was found much more difficult to mask this note, two roaring bunsens close to the microphone being required. The analysis appeared less efficient in distinguishing the fork note from the background, the ratio of fork response to background disturbance being of the order 8 : 1. The galvanometer disturbance due to the background showed a maximum when the speed of interruption was of the order of 1000/sec. Previous experiments have shown that this is the resonance region of the microphone.

The masking effects of backgrounds appear to be of considerable interest and importance, and require fuller investigation.

ANALYSIS OF SOUND IN WATER.

It was decided to give special attention to low frequencies ranging from about 5–150/sec. A number of low-frequency sounders and receivers of different types were used, and will be described before the experiments.

(a) *Sources of Sound.*

(1) *Cylindrical Sounder.* (A type used by Lord RAYLEIGH for experiments in air, ‘Phil Mag.’, 1907.)—This was a metal can maintained in bell-like vibration by means

of an electromagnet excited by a current of about 1 ampere from a spring-interrupter using 4 volts. Two sizes of this type of sounder were constructed. These were generally driven at their natural frequencies.

	No. 1.	No. 2.
Length	12·8 cm.	16·1 cm.
Diameter	7·8 cm.	9·4 cm.
Thickness	0·68 mm.	0·30 mm.
Natural frequency in water	111/sec.	21/sec.

With these sounders the intensity fell off exceedingly rapidly with the distance, probably owing to consecutive segments moving in opposite phases causing short-circuiting of the vibrations in the water. They have also directional properties, the sound being sent out radially with four symmetrically placed maxima. The rapid falling off of intensity with distance is an advantage in tank experiments, where multiple reflections are a source of disturbance.

(2) *Double Diaphragm Sounder*.—This is non-directional, and on account of its great range has been used in most of the experiments carried out in the reservoir.

It consisted of a shallow cylindrical cavity closed by two vertical metal diaphragms, one of which carried at its centre an electromagnet, and the other an equal mass of soft iron (fig. 8). The electromagnet was excited by an intermittent current from a spring-interrupter. The space between the diaphragms communicated with the water by a small hole at the bottom. The apparatus could be used either completely filled with air or filled with water, with the exception of a small chamber of about 30 c.c. near the top of the cavity, in which the air remained trapped. The sounder was held by a 12-ft. iron rod, by means of which it could be lowered over the side of a boat to the desired depth. When used air-filled, a long piece of pressure tubing was attached to the cavity and air pumped in until the air-bubbles escaping from the hole at the bottom were seen rising in the water. In the boat from which the sounder was hung were the cells (4 volts) and the spring-interrupter, these being connected by long leads to the electromagnet within the sounder (current 2–2½ amperes). The boat could be anchored in any desired position, and the apparatus when once adjusted would run for hours at a time without attention.

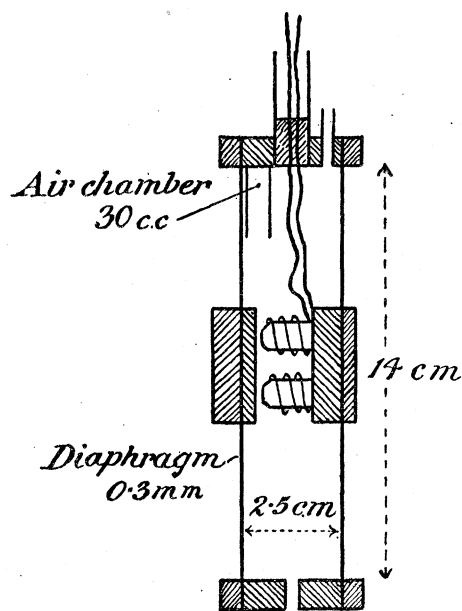

Fig. 8. Double diaphragm sounder (section).

The natural frequency of this sounder depended on the internal conditions. The

restoring force on the diaphragm was mainly due to the elasticity of the air in the cavity (the restoring force due to the elasticity of the diaphragm being relatively unimportant) giving when air-filled a natural frequency of about 67/sec., the exact value increasing with the depth of the sounder below the surface, the variation being roughly $\frac{1}{2}$ per cent. per foot. Although the effect of introducing water into the cavity is to increase the effective inertia of the diaphragms, the frequency is raised on account of the greatly increased restoring force given by the residual air. With the 30 c.c. of air generally used the natural frequency was about 123/sec. In practice the sounder was generally driven near the natural frequency corresponding to the working conditions; the maximum energy is then emitted, and as a nearly pure tone. If driven at much lower frequencies the intensity was diminished, and, as would be expected, any harmonic near resonance with the natural frequency of the diaphragm became prominent.

(3) *Single Diaphragm Sounder*.—A thin iron diaphragm was bolted on to the end of a massive cylindrical iron pot (fig. 9). A mass (380 gm.) of soft iron was attached

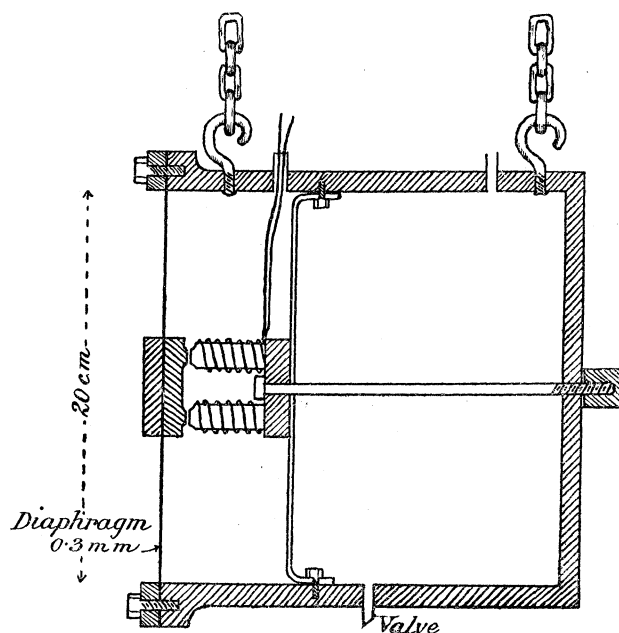

Fig. 9. Single diaphragm sounder (section).

to the centre of the diaphragm, behind which the exciting magnet was rigidly held. The cavity was always air-filled at the pressure of the surrounding water in order to avoid distortion of the diaphragm. The sounder was hung from a punt by a double chain at a depth of $4\frac{1}{2}$ feet.

The instrument was found to be unsatisfactory in practice owing to the extreme sensitiveness of the diaphragm to changes of pressure due to small variations in depth. It had a natural frequency in water of 47/sec., a value much higher than was expected. The effect of the restoring force due to the air-cavity can be avoided by using a single diaphragm with both sides in contact with the water, but such an instrument would

not be an efficient radiator for low frequencies in consequence of short-circuiting action referred to above, and also it would be bi-directional.

(4) *Evinrude Row-boat Motor*.—To obtain a more powerful and complex source an Evinrude row-boat motor was used.

This was a 2–3 h.p. single-cylinder, two-cycle petrol motor fitted with a two-blade propeller. In most of the experiments it was attached to the stern of a 13-ft. centre-board sailing dinghy, which either circled round the receiving instrument or was kept in a fixed position, about 100 feet out, by steel wires made fast to posts on the bank of the reservoir. The frequency of the piston, which must be regarded as the fundamental frequency, could be varied from about 10–11/sec. when the boat was fixed, while a frequency of 14·5/sec. could be obtained when the boat was in motion. During a single experiment the motor was found to run at a very constant frequency, and proved to be a very convenient source of vibration for the purpose of analysis.

(b) *Receivers*.

In all the water experiments described below attention was usually confined to the range of frequency 5–150/sec.

In order to obtain a faithful analysis the receiver should be either non-resonant or its resonance frequency should be well above the range under investigation. In the latter case the receiver will be insensitive in this range, and the results of the analysis will be complicated by the disturbance of subharmonics of the diaphragm frequency (see p. 144). We did not succeed in devising an ideal receiver for low-frequency vibrations, although fairly satisfactory results were obtained with the Rubber Diaphragm Receiver. Owing to damping the latter did not give unduly sharp resonance, and its resonance frequency could be varied to eliminate selective action.

(1) *Metal Diaphragm Receiver*.—The construction of this instrument is shown in fig. 10. Owing to the thinness of the diaphragm, it is necessary to compensate the external water-pressure. This was done by putting the air cavity in communication with a cylindrical reservoir the lower end of which was provided with a small hole to admit the water. If the cross-section of the cylinder is sufficiently great, then it is easily seen that the level of the water in it will not alter much with change in depth, and hence the air-pressure in the instrument will remain approximately at the pressure of the water outside. By adjusting the level of the reservoir with respect to the diaphragm, the compensation can be made exact for any particular depth.

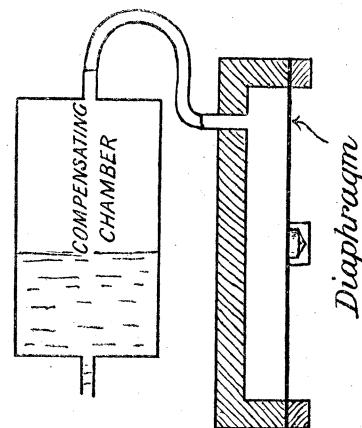

Fig. 10. Metal diaphragm receiver (section).

The microphone was attached by its base to the centre of the diaphragm, and enclosed

in a small sealed box. The diaphragm was of tinned iron, 10 cm. diameter and 0.3 mm. thick, and with a natural frequency in water of 120/sec.

(2) *Rubber Diaphragm Receiver with Adjustable Natural Frequency.*—With this instrument the object was to obtain a much lower natural frequency. The effect of the air-cavity in giving an additional restoring force to the diaphragm, as already referred to under “Sounders,” has now to be taken into account. In this receiver the diaphragm was made of very thin rubber, so that the restoring force was almost entirely due to the enclosed air. Advantage was taken of this fact to make the instrument of adjustable frequency by changing the volume of the air-cavity behind the diaphragm. The principle of compensation for hydrostatic pressure described above was again applied.

The diaphragm, with the microphone attached at its centre, formed one end of a brass tube 30 cm. long and 5 cm. in diameter, the opposite end being closed by a screwed cap (fig. 11). Inside the brass tube was a solid brass plunger the position of which

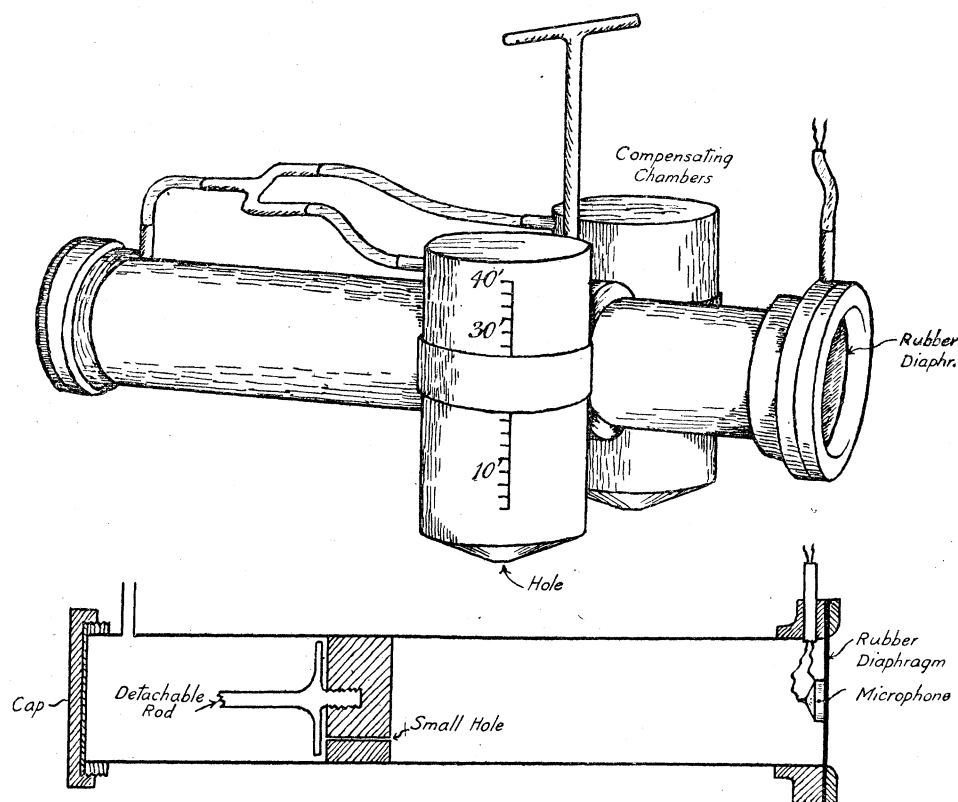

Fig. 11. Rubber diaphragm receiver.

could be varied by means of a detachable rod. A very small hole in the plunger allowed equalisation of pressure on either side, while at the far end of the cylinder was a side tube communicating with two symmetrically placed compensating chambers. The total volume of the cylinder was 600 c.c., and the chambers were 500 c.c. each. This allowed a compensation to be made for depths down to 40 feet. For convenience in setting the chambers, a scale of depths was marked on the sides.

Using the full volume of the tube, the natural frequency was 40/sec., and when the plunger was pushed up within a few centimetres of the diaphragm the natural frequency became about 100/sec. There was considerable damping, as a result of which the natural frequency was not pronounced, and was difficult to determine.

Listening Arrangements.—In most of the experiments it was found useful to put a telephone in the receiver circuit in place of the galvanometer and interrupter in order to listen to the sound. Such observations are recorded below as “sound in telephone.”

In the case of low-frequency vibrations, *e.g.* 50/sec., the sound in the telephone does not give a reliable indication of the character of the vibration in the water, since for such a frequency the telephone responds only to the harmonics, and if they are not present then no sound is heard.

A Broca tube also served as a useful listening device. The diaphragms were flat sheets of tinned iron, 15 cm. diameter. The natural frequency in water was approximately 100/sec., and showed marked tuning with depth due to change in pressure. The sounder 123/sec. could be heard at a distance of 400 yards.

It was found that a short length of rubber tube, 1 cm. external diameter, walls 2 mm. thick, formed a simple type of non-resonant Broca tube. The lower end was sealed and weighted with a lead sinker, the upper end was connected to a stethoscope.

Except the cylindrical sounder first described, both sounders and receivers were non-directional.

(c) *Reservoir Experiments with Sounders.*

The Barnt Green Fishing and Boating Club kindly gave permission to make use of Great Bittell Reservoir (near Birmingham), together with a number of boats, &c., for experimental purposes. The reservoir has an area of 100 acres, with a maximum depth of 40 feet. The receivers were connected to the shore by cable, and the analysis was made in the boathouse where the interrupter and 100-ohm Broca galvanometer were set up. With few exceptions it was found impossible even in the calmest weather to use the receivers when hung from a moored boat, since a very small motion at the point of support produced a large disturbance on the galvanometer. Satisfactory results were only obtained when the receiver was either hung from a tripod or placed directly on the bottom of the reservoir. The tripod was constructed from bamboos 11 feet long and provided with a sinker on each foot. When in the required position, the lowering rope was sunk with a lead weight in order to prevent surface disturbances being directly communicated to the apparatus. In some experiments a small cork marker was used to indicate the position of the tripod.

Determination of Natural Frequency of Sounders and Receivers in Water.—This presented considerable difficulty, and it may be of interest to indicate the different methods which have been used.

Sounders :—

- (i.) A platinum contact was attached to the diaphragm, and the sounder made self-driving after the manner of an electrically maintained fork. The frequency was then determined either by analysis of the current induced in a single turn of wire acted on inductively by the circuit, or by analysis of the current generated by a U-magnet attached to the sounder diaphragm. The platinum contact worked quite well under water, but this system of driving the sounder was not suitable for general use.
- (ii.) With the sounder immersed, the diaphragm was gently tapped with a rubber hammer at intervals of 1 second, and an analysis made of the current induced in the windings of the electromagnet, as in earlier experiments on the analysis of damped vibrations.

Receivers :—

- (i.) By experiments in which a sounder was driven at various frequencies and the receiver used to obtain a resonance curve.
- (ii.) The natural frequency of the diaphragm was excited by impulses such as an oar-splash or a tap on a neighbouring boat. In the latter case the analysis showed in addition the natural vibration of the boat.
- (iii.) A method more satisfactory than the last was to analyse the general water disturbance on a rough day. (Compare experiments on Analysis of Background, p. 146.)

Metal Diaphragm Receiver (Natural frequency, 120/sec.).—This instrument in moderately calm weather could be used, when hung from an anchored boat with a galvanometer disturbance of no more than about 1 div., corresponding to a faint background in the telephone. Under rougher conditions a strong diaphragm noise was produced in which on certain occasions the separate impulses could be identified with the lapping of the water against the boat. The sounder could be distinctly heard at a distance of 60 feet.

With this instrument remarkable variations of the intensity of the sound with depth were observed, showing the existence of an almost silent layer on the bottom. Slowly raising the receiver from the bottom to the surface showed a rapid increase in the first 6 feet, followed by a slower falling off towards the surface, the maximum occurring at 6–9 feet from the bottom. The observed amplitude at 6 feet was in some cases 25 times that at 1 foot from the bottom. The sound in the telephone varied in a similar way. These effects as tested by the telephone appeared to be the same in different parts of the reservoir, where the depths were 12, 18 and 32 feet, and independent of the frequency which ranged from 60–130/sec. Sounds due to taps on the boat, splashing of oars, &c., and also natural disturbances, were modified in the same way. No definite effect of this kind was observed when using the other receivers of lower frequency.

The amplitude of the vibration fell off with horizontal distance from the source with

remarkable rapidity. Putting amplitude $\propto \frac{1}{(\text{distance})^p}$, the value of the index p (see below) is generally 3 to 3.5, which makes the energy fall off with the sixth or seventh power of the distance. This gives rise to considerable difficulty in making exact measurements, as a large error is introduced by a small change in distance.

The variation in amplitude with distance and depth is shown in the following examples:—

Depth of water.	Frequency of sounder.	Depth of sounder.	Depth of receiver.	Horizontal distance.	Response.	Index p .
ft. 12	105	ft. 6	ft. On bottom.	ft. 4 45 75	Off scale >250 18 3	3.5
15	124	10	9 9 9 On bottom 6	40 80 130 80 80	270 25 <5 3 16	3.5 >2.6
17	66.5*	3	11 11 On bottom 9 3	135 60 60 60 60	7 80 3 150 80	3.0

Rubber Diaphragm Receiver.—When hung from a boat in very calm weather the galvanometer showed oscillations of 20–40 div. with an occasional 200 divs., but on the bottom the disturbance was reduced to 1–2 div. A residual disturbance of this magnitude was always present under the quietest conditions, even when out of the water, and this may represent the natural limit of steadiness of the microphone. The instrument was used either on the bottom or on the tripod, and even then quiet weather was essential. On a windy day there were large disturbances always closely associated with the gusts. Their magnitude was not changed by altering the natural frequency of the receiver.†

With this apparatus a number of experiments were made in which the sounder was

* In this case the weak octave 133/sec. present in the sounder was reinforced by resonance with the receiver. This response varied with depth in the same way as the fundamental.

† Some experiments made in the laboratory at a later date furnished the explanation of these disturbances. It will be seen from the construction of the apparatus that slow pressure changes can be communicated to the air cavity through the compensating reservoirs. Such pressure changes would not produce any motion of the diaphragm. The effects on the microphone are due to the direct action of the air pressure on the lid of the button. This was confirmed by blowing air into the cavity of the instrument. It was then found that when the microphone was subjected to a sustained additional pressure the microphone current showed a rapid increase followed by a slow exponential recovery, the transformed current causing

driven successively at different frequencies. Since the driving current contains harmonics the forced motion of the sounder will also contain these harmonics, and if the frequency of one of them is near the natural frequency, then on account of resonance that harmonic will be very prominent, and may be much greater than the fundamental. But the receiver also has a selective action, and will enhance by resonance any harmonic which is near its natural frequency. These effects were observed in the analysis but will not be further described.

The variation of amplitude with distance was determined using the two sounders near their natural frequencies, and the results obtained are given in the following table :—

Depth of water.	Frequency of sounder.	Depth of sounder.	Depth of receiver.	Horizontal distance.	Response.	Index p .
ft. 18	44.5	ft. 4.5	ft. 12	ft. 57 150	190 9	3.1
17	58	9	On bottom.	60 165	180 <5	>3.5

The high value of the index is in agreement with the results obtained with the Metal Diaphragm Receiver.

A particular source of disturbance with the Rubber Diaphragm Receiver was found to be due to the vibrations caused by trains passing at a distance of rather more than a quarter of a mile. The effects were noticed when analysing in the region 30–40/sec., where on occasions definite responses of over 100 div. were obtained. These disturbances greatly added to the difficulty of the experiments, especially when examining vibrations of very small amplitude.

(d) *Sound Spectrum of Evinrude Motor* (Reservoir experiments).

A description of the motor together with the general arrangements has already been given (p. 149). Analysis was made with both receivers. They were either placed on the bottom or hung from the tripod 6 feet above the bottom. In each case a spectrum was obtained consisting of a harmonic series, n , $2n$, $3n$, $4n$, &c., having for its fundamental the frequency n of the motor. In general the higher harmonics have smaller intensities, and only in a few special cases could measurements be extended beyond the first ten harmonics.

the galvanometer to give a complete oscillation, as would be expected. The exponential recovery, which extended over some 15 sec., was evidently due to the air leaking into the partially air-tight button. *The whole effect completely disappeared when a small hole was drilled through the side of the button.*

It was thought that the instrument might now be less sensitive to low frequency vibrations. An experiment in a tank showed that for a frequency of 100/sec. the sensitiveness was reduced to about one-half.

It would thus appear that in the reservoir experiments the wind pressure was transmitted through the water to the receiver. The metal diaphragm receiver did not show these effects since its button is enclosed in a sealed cavity.

The Rubber Diaphragm Receiver was found to be much more satisfactory than any other type tried, and was used in all the experiments described below.

Variation of Spectrum with Motor Speed.—It was soon found that even under closely identical conditions the character of the spectrum often differed greatly on repeating the experiments. It has not been found possible to explain this variation completely, but it is partly due to change in motor frequency. Experiment showed that quite small variations in the motor frequency—variations originally regarded as of little consequence—may greatly affect the relative intensities of the “lines” in the spectrum. There are several ways in which this may take place:—

- (i.) In the experiments the motor speed was always changed by altering the phase of the ignition; this may result in a change in the character of the vibration of the motor itself.
- (ii.) Mere change of speed may bring certain harmonics into, or out of, resonance with natural frequencies of the boat.
- (iii.) Change of speed may bring certain harmonics into resonance with the receiver.

Experiments show that (iii.) at least is an important factor. Unfortunately, the frequency of the Evinrude motor (with boat fixed) can only be varied by about 10 per cent., *i.e.* from 10–11/sec.

Three examples of the variations in the spectrum are given in fig. 12, where the

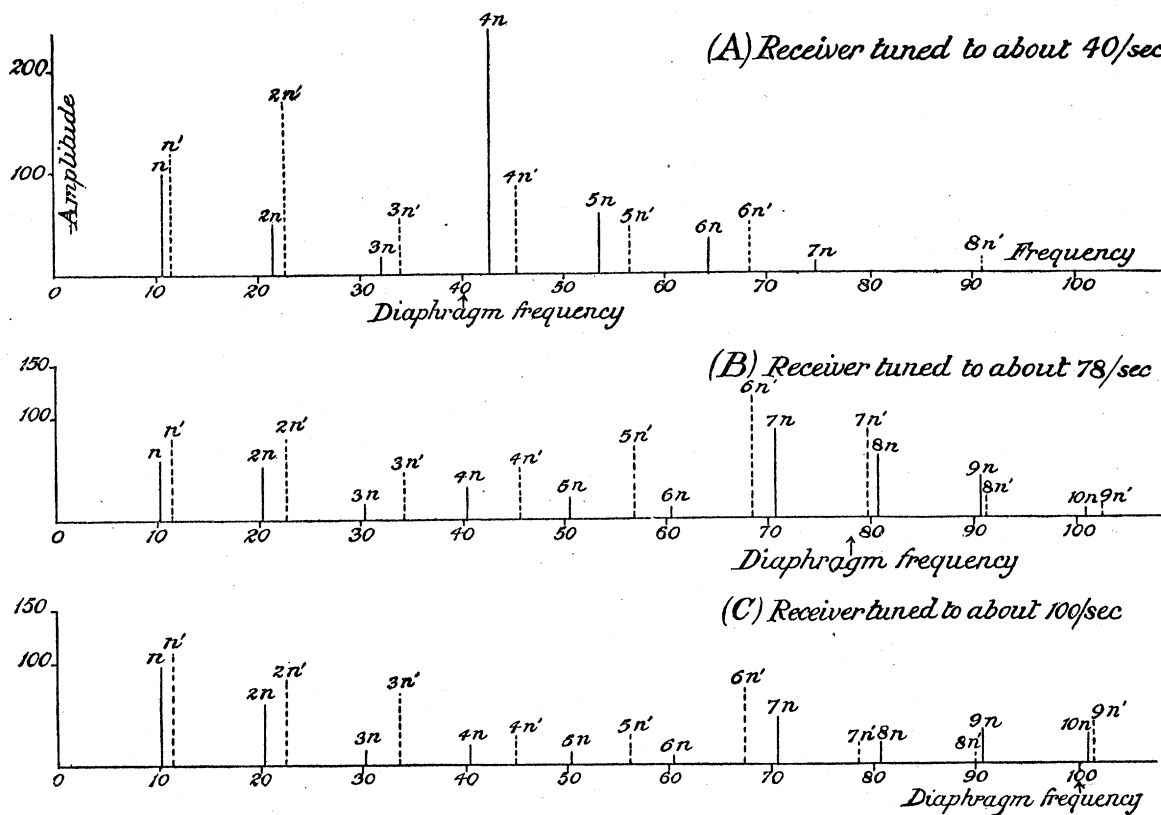

Fig. 12. Variation of spectrum of Evinrude with motor speed and natural frequency of receiver. Depth, 15 feet. Receiver on bottom. Distance 13 feet; broadside on.

harmonic series for low and high speeds are represented by continuous and broken lines respectively. All three experiments were carried out under identical conditions as regards the position of the receiver, which was placed on the bottom at a depth of 15 feet. The only difference made in the conditions was in the natural frequency of the receiver: in the first experiment this was made as low as possible, about 40/sec., by using the full volume of the air-cavity; in the second it was raised to about 80/sec., and in the last to about 100/sec. The last two natural frequencies are only known approximately.

It will be seen that in all three cases the responses n , $2n$, $3n$, are increased with increased speed. In the first experiment $4n$ is very prominent, and showed a decrease with speed, evidently due to its being put out of resonance with the diaphragm. The effect of diaphragm resonance is also shown in the second and third experiments, which give strong responses near 80 and 100 respectively, frequencies for which no responses were detected in the first experiment. On the other hand, there seem to be certain permanent features in the spectrum—for example, the third harmonic for the lower speed always being very weak, and the harmonic near 68 being always prominent. These characteristics may be associated with either the boat or the motor.

Variation of Spectrum with Direction.—The receiver was placed in various directions with respect to the axis of the boat, the distance from the propeller being constant. Variations in the spectrum were observed, but as consistent results were not obtained on repeating the measurements for any one position, no definite conclusions can be drawn. In general the experiments showed that direction has no *marked* influence on either the intensity or distribution in the spectrum.

Variation of Spectrum with Depth.—It was not possible to moor the motor-boat in the deeper parts of the reservoir. Some experiments were therefore made with the motor circling round a cork marker indicating the position of the receiver, which was—(a) on bottom, (b) on tripod 6 feet above bottom. The depth of water was 26 feet, and the radius of the circle either 20 feet or 60 feet. The spectrum of the *boat in motion* did not differ essentially from results obtained with the boat moored in shallow water. The motor frequency was 14·2/sec. instead of 10–11/sec., so that no exact comparison is justifiable. The intensities observed were less than those for equal horizontal distances in shallow water, but not in greater proportion than is accounted for by the greater actual (oblique) distance between receiver and boat.

Variation of Amplitude with Distance.—Experiments were made to determine the variation of amplitude with distance in the case of the most prominent vibrations up to the fifth harmonic. The most useful results would be obtained at distances great compared with the dimensions of the boat, but on account of the rapid decrease in intensity it was quite impossible to make observations at distances greater than 70 feet. At these distances disturbances were comparable in magnitude with the effects to be observed.

Since the source is on the surface and receiver on or near the bottom, any change in

distance also involves a change in direction with respect to the vertical, and if nodal planes exist in the water one would expect a more complex relation than that given by the former experiments using non-directional sounders. There is the additional complication due to reflection from top and bottom, which will be different in the two sets of experiments owing to the sounder always being placed below, instead of on, the surface.

Putting, as formerly (p. 153), amplitude $\propto \frac{1}{(\text{distance})^p}$, the values of the index p for the different harmonics are given in the following table:—

Depth of water.*	Frequency, n .	Responses at horizontal distance.				Index p .	
ft. 13	11.1	(14 ft.)		(24 ft.)			
		n	90	25		2.4	
		$2n$	210	100		1.4	
		$3n$	130	37		2.3	
		$4n$	230	60		2.5	
		$5n$	40	7		3.2	
16	11.2	(13½ ft.) (21 ft.) (43 ft.) (69 ft.)					
		n	80	25	5	0	2.4†
		$2n$	45	25	10	0	1.3†
		$3n$	45	10	10	5	—
		$4n$	140	70	23	10	1.6†
26 Boat circling.	14.2	(21 ft.)		(42 ft.)			
		n	28	15			0.91 (1.1)‡
		$2n$	14	5			1.5 (1.6)‡
		$3n$	25	3			3.1 (4.9)‡

The distances given in the table are horizontal distances, and these differ from the true distances more in deep than in shallow water. This correction has not been made, as it does not appear to lead to a simpler law.

In fig. 13 the values of the log (amplitude) are plotted against log (distance) for the third experiment in the table, in which the greatest range of distance was covered. It will be seen that the graphs for n , $2n$ and $4n$ are practically straight lines giving a constant value for p as determined by the slope of the line in each case. The results

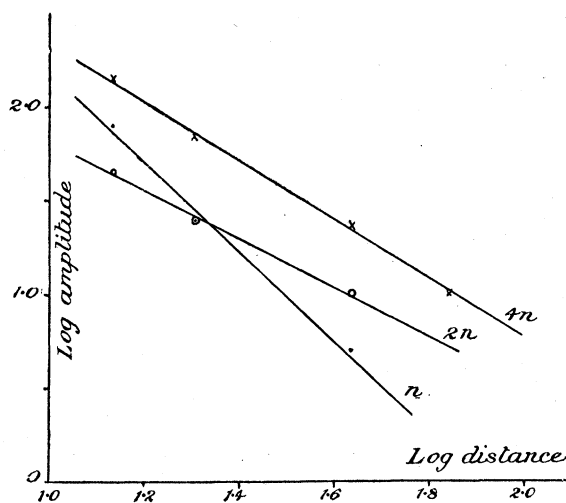

Fig. 13. Variation of amplitude with distance—
Index graph.

* The receiver was 6 feet above the bottom.

† From graph, fig. 13.

‡ These values of p are calculated for the oblique distances.

for $3n$ are quite abnormal, as no falling off in amplitude was observed for the distances 21 feet and 43 feet. This is the only occasion on which such an effect has been recorded, and may be accounted for by accidental disturbance.

The table shows that in any one experiment the various harmonics have different values of the index p , indicating that the character of the spectrum really changes with the distance, but the values of p depend on the experimental conditions. The range of p is from 1 to 5, and in general the higher harmonics fall off most rapidly with the distance (*i.e.*, have larger values of p) and the harmonic $2n$ least rapidly of all. It is not known whether this peculiarity of $2n$ is associated with the absolute frequency or with the propeller action in which this vibration may have its origin.

The distances were always measured from the propeller, but it appeared that the propeller only acts as an additional source. One can see the sides of the boat vibrating, and in calm weather the ripples radiating from the stationary boat are quite evident.

On several occasions the boat-vibration was examined by placing in the boat a frequency-meter of the vibrating reed type. Within the range of this instrument (25–50/sec.) responses were obtained corresponding to the harmonics which were simultaneously detected in the water. With the rubber diaphragm receiver used in these experiments the sound in the telephone was distinct up to 50 feet. Listening directly with the Broca tube and rubber tube, the sound was poor even at distances of about 20 feet.

Subharmonics.—In the diagrams representing the spectrum of the Evinrude motor the subharmonics have, for the sake of clearness, been omitted. As the higher harmonics are generally small, and not observable beyond the tenth, there were very few subharmonics to confuse the analysis. Most of the subharmonics were below the fundamental, and this region was disregarded in the analysis. The fundamental response often showed some irregularity due to the superimposed subharmonic $\frac{1}{3}(3n)$.

The measurement of the amplitudes of the vibrations up to the tenth harmonic occupies about 10 minutes.

Analysis by Telephone.—It is interesting to note that by putting a telephone (in place of the galvanometer) in series with the interrupter the fundamental frequency (10/sec.) of the Evinrude motor can be determined with great precision, as the beats are very marked when the interrupter is running near that frequency. Also the frequency of the harmonics can be determined in a similar way, although with them the effect is not so evident.

PART II.—THE THEORY OF ANALYSIS OF AN ELECTRIC CURRENT BY PERIODIC INTERRUPTION.

The present paper contains an account of the theory of the analysis of an alternating current by the method of periodic interruption. The experiments in which this method has been applied for the analysis of sounds in air and water are described in Part I.

Let the current to be analysed be a function of the time expressed by

$$y = f(t)$$

and represented by (a) in fig. 14. We may regard the effects of interruption as merely

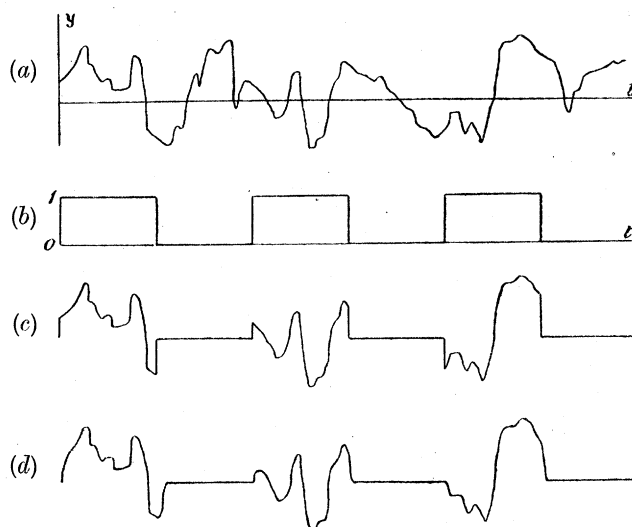

Fig. 14. Interruptions of current.

the result of multiplying the instantaneous value of the current y by a factor which has periodically the values 1 and 0. For equally spaced interruptions of frequency n^* and giving equal time intervals for open and closed circuit, this factor is represented graphically by the periodic form (b) (fig. 14), and has for its expression the Fourier series :

$$\frac{1}{2} + \frac{2}{\pi} (\sin nt + \frac{1}{3} \sin 3nt + \frac{1}{5} \sin 5nt + \&c.).$$

The resulting intermittent current, represented by (c) (fig. 14), is therefore given by

$$y' = \left\{ \frac{1}{2} + \frac{2}{\pi} (\sin nt + \frac{1}{3} \sin 3nt + \frac{1}{5} \sin 5nt + \&c.) \right\} f(t).$$

This expression must now be resolved into S.H. components. These may then be regarded as forces of S.H. type acting on the galvanometer system—or on the telephone diaphragm—and giving rise to a forced motion which is readily calculated. If the galvanometer possesses very little damping, only those components which have a frequency near that of the galvanometer will produce any appreciable motion. But we shall suppose, in accordance with experimental requirements, that the galvanometer is heavily damped, and for convenience we shall here take it as being exactly “dead-beat.” Under these conditions there will be no resonance, and a component is only

* The quantities $n, n_1, n_2, p, \&c.$, really angular velocities, are, for the sake of brevity, here referred to as frequencies, the 2π being everywhere omitted. They are strictly the radian frequency of phase change.

effective in producing appreciable motion when its frequency is *less* than that of the (undamped) galvanometer. The full amplitude of the component is not exhibited by the galvanometer unless the component has zero frequency; if it has half that of the galvanometer the amplitude of the motion produced is 80 per cent. of the full value (see fig. 15, which shows how the forced amplitude varies with the frequency p of the force).

On the other hand, a telephone in the circuit will render audible only those components which are of sufficiently high frequency to excite the diaphragm and the ear.

If the circuit contains appreciable self-induction the effects of interruption are greatly complicated—at least theoretically—and special assumptions as to the conditions which hold at “break” must be made in order to proceed with the investigation. The general effect will be to round off the sharp corners at “make” and “break” in curve (*c*) (fig. 14) as represented in curve (*d*). Provided the “time-constant” of the circuit is small, only the components of high frequency will be seriously modified by self-induction. The order of frequency affected is $1 \div$ (time-constant), or R/L if the circuit has resistance R and induction L . (For a Broca galvanometer alone R/L is about 1200/sec.)

Actually we are not likely to be greatly concerned with the modification introduced, for this would imply that we are using the analysis to determine a component of frequency so high that, on account of ordinary impedance, it already must have undergone considerable distortion. We shall, therefore, neglect self-induction and proceed to consider certain special types of current.

(1) *Steady Direct Current.*

$$y = A, \text{ a constant.}$$

Then

$$y' = \frac{A}{2} + \frac{2A}{\pi} (\sin nt + \frac{1}{3} \sin 3nt + \&c.).$$

The galvanometer is deflected by $A/2$. The sound in the telephone is represented by the uneven harmonic series of tones with the interruption frequency n as fundamental. This is the “interrupter note”; it is characterised by the wave-form (*b*) (fig. 14). When n is very low only the numerous high harmonics in the audible region are effective, and the sound is well described as a purr. As n is increased the note becomes more musical in quality, and its pitch is recognisable.

(2) *S.H. Current.*

$$y = A \sin n_1 t.$$

Putting $A \sin n_1 t$ in place of $f(t)$ in the general equation for y' , this may be written :

$$y' = \frac{A}{2} \sin n_1 t + \frac{A}{\pi} \left\{ \cos (n - n_1) t - \cos (n + n_1) t + \frac{1}{3} \cos (3n - n_1) t - \frac{1}{3} \cos (3n + n_1) t \right. \\ \left. + \frac{1}{5} \cos (5n - n_1) t - \frac{1}{5} \cos (5n + n_1) t + \&c. \dots \right\}.$$

The tones present are therefore

$$n_1, \quad n \pm n_1, \quad 3n \pm n_1, \quad 5n \pm n_1, \quad \&c.$$

The difference tones $n - n_1$, $3n - n_1$, &c., have zero value of frequency when

$$n = n_1, \quad \frac{1}{3}n_1, \quad \frac{1}{5}n_1, \quad \&c.,$$

with the amplitudes

$$\frac{A}{\pi}, \quad \frac{1}{3}\frac{A}{\pi}, \quad \frac{1}{5}\frac{A}{\pi}, \quad \&c.$$

These represent the fundamental and "subharmonic" responses.

We shall now suppose we are running through the fundamental response so that $n = n_1$ nearly. Put $n - n_1 = p$ where p is the small difference in frequency between interrupter and current. In going up, *i.e.* with increasing speed, through the response p changes from negative to positive.

The general expression may now be written

$$y' = \frac{A}{2} \sin n_1 t + \frac{A}{\pi} \left\{ \cos pt - \cos (2n-p)t + \frac{1}{3} \cos (2n+p)t - \frac{1}{3} \cos (4n-p)t \right. \\ \left. + \frac{1}{5} \cos (4n+p)t - \frac{1}{5} \cos (6n-p)t + \&c. \right\}.$$

The frequencies of the components are

$$p, \quad n_1, \quad 2n \pm p, \quad 4n \pm p, \quad 6n \pm p, \quad \&c.$$

The galvanometer responds to p . It is seen that there is a series of beating tones, $2n$, $4n$, $6n$, &c., and all these beat with the *same* frequency $2p$, *i.e.* twice the frequency of the oscillations of the galvanometer at the same instant (confirmed by experiment). The amplitudes of the beating tones are never equal, but they tend to equality for the higher harmonics of the series. This explains the beating which is heard in the telephone even when n_1 is well below the limits of audibility.

For synchronism ($p = 0$) there is produced the single note of fundamental n_1 containing the *even* harmonics $2n$, $4n$, &c. The original *tone* n_1 may be inaudible, and in any case it is weakened by interruption, but the addition of the harmonics will in general render audible the resulting *note* n_1 .

When n is near $2n_1$ put $n - 2n_1 = p$. The component frequencies are then

$$n_1, \quad n_1 + p, \quad 3n_1 + p, \quad 5n_1 + 3p, \quad 7n_1 + 3p, \quad \&c.$$

In this case there is no galvanometer response. There is only one beating pair, n_1 , $n_1 + p$, the amplitudes $A/2$, A/π of which are sufficiently near equality to give a marked beating, but, of course, this will not be heard unless n_1 is within the audible range. It will be noted that the beats have the frequency p in this case, instead of $2p$ as above.

Similarly, when n is near $3n_1$ it is easily shown that there is no response and no beating. [Confirmed by experiment.]

Now take n near $\frac{1}{3}n_1$ and put $3n - n_1 = p$. Then

$$y' = \frac{A}{2} \sin n_1 t + \frac{A}{\pi} \left\{ \cos (2n-p)t - \cos (4n-p)t + \frac{1}{3} \cos pt - \frac{1}{3} \cos (6n-p)t \right. \\ \left. + \frac{1}{5} \cos (2n+p)t - \frac{1}{5} \cos (8n-p)t + \frac{1}{7} \cos (4n+p)t - \&c. \right\}.$$

Hence the frequencies are

$$p, \quad n_1, \quad 2n \pm p, \quad 4n \pm p, \quad 6n \pm p, \quad \&c.$$

The galvanometer responds to p ; this is the third order subharmonic of amplitude $A/3\pi$. The beating pairs all beat with the same frequency $2p$, but their amplitudes are more unequal than in the case of the fundamental response.

(3) Harmonic Series.

Let the original current be

$$y = A_1 \sin n_1 t + A_2 \sin 2n_1 t + A_3 \sin 3n_1 t + \&c.$$

without regard to phase differences between the constituents.

The interrupted current is now made up of groups of components, there being one group associated with each harmonic. It is sufficient to consider only the case of synchronism with the fundamental of the series, *i.e.* when $n = n_1$ nearly. Putting $n - n_1 = p$ as before, the resulting tones may be tabulated thus:—

Amp. ratio.	$A_1.$		$A_2.$		$A_3.$		$A_4.$		$A_5.$	
	$n_1.$		$2n_1.$		$3n_1.$		$4n_1.$		$5n_1.$	
1	p	$2n-p$	$n-2p$	$3n-2p$	$2n-3p$	$4n-3p$	$3n-4p$	$5n-4p$	$4n-5p$	$6n-5p$
$\frac{1}{3}$	$2n+p$	$4n-p$	$n+2p$	$5n-2p$	$3p$	$6n-3p$	$n-4p$	$7n-4p$	$2n-5p$	$8n-5p$
$\frac{1}{5}$	$4n+p$	$6n-p$	$3n+2p$	$7n-2p$	$2n+3p$	$8n-3p$	$n+4p$	$9n-4p$	$5p$	$10n-5p$
$\frac{1}{7}$	$6n+p$	$8n-p$	$5n+2p$	$9n-2p$	$4n+3p$	$10n-3p$	$3n+4p$	$11n-4p$	$2n+5p$	$12n-5p$

The interrupted current may be regarded as made up of

(a) $\frac{1}{2} (A_1 \sin n_1 t + A_2 \sin 2n_1 t + \&c.).$

This is the original note with half the amplitude.

(b) $\frac{1}{\pi} (A_1 \cos pt + \frac{1}{3} A_3 \cos 3pt + \frac{1}{5} A_5 \cos 5pt + \&c.).$

This is the galvanometer response, which now has a complex character due to the superimposed subharmonics of $3n_1$, $5n_1$, &c.

(c) The beating tones

$$\begin{aligned} \frac{A_1}{\pi} [(1, \frac{1}{3}) 2n \pm p, \quad (\frac{1}{3}, \frac{1}{5}) 4n \pm p, \quad (\frac{1}{5}, \frac{1}{7}) 6n \pm p, \text{ \&c.}] \text{ beating at } 2p, \\ \frac{A_2}{\pi} [(1, \frac{1}{3}) n \pm 2p, \quad (1, \frac{1}{5}) 3n \pm 2p, \quad (\frac{1}{3}, \frac{1}{7}) 5n \pm 2p, \text{ \&c.}] \text{ beating at } 4p, \\ \frac{A_3}{\pi} [(1, \frac{1}{5}) 2n \pm 3p, \quad (1, \frac{1}{7}) 4n \pm 3p, \quad (\frac{1}{5}, \frac{1}{9}) 6n \pm 3p, \text{ \&c.}] \text{ beating at } 6p, \\ \text{\&c.}, \end{aligned}$$

where the numbers in () brackets indicate the relative amplitudes of the beating pairs.

The sound in the telephone is, therefore, remarkably complex. It will be noticed that the constituents of the original note (*a*) have frequencies which may be written

$$n + p, \quad 2n + 2p, \quad 3n + 3p, \quad \text{\&c.}$$

and these can be associated with components in (*c*) to give beating at frequency *p*. This appears to be the explanation of the curious fact that in an experiment with a current rich in harmonics the beating heard agrees in frequency with the galvanometer oscillations *p*, although with a S.H. current the beating frequency has the double value *2p*. Examination of the above table shows that this abnormal beating at *p* depends essentially on the co-operation of *consecutive* harmonics of the original current. In all cases the ear appears to appreciate only the slowest beats which are present.

The more general case in which the interruptions are of unequal intervals and unequally spaced may be treated in a similar way to the above. It is only necessary that the interruptions shall be strictly periodic so that they may be represented by a Fourier series.

Simple Response.—If the galvanometer system has a natural undamped period $\frac{2\pi}{n_0}$ and is made exactly dead-beat, the equation of motion due to a S.H. force is

$$\ddot{x} + 2n_0\dot{x} + n_0^2x = F \cos pt.$$

The solution of this for the steady state gives the amplitude of motion

$$a = \frac{F}{n_0^2 + p^2}.$$

When the frequency *p* of the force becomes very small compared with that of the galvanometer *n*₀, the amplitude has the maximum value $a_m = \frac{F}{n_0^2}$ corresponding with the centre of the response.

Hence

$$\frac{a}{a_m} = \frac{n_0^2}{n_0^2 + p^2}.$$

Plotting a/a_m against p/n_0 we obtain the response curve (equation $y = \frac{1}{1+x^2}$) shown by the full line in fig. 15. The amplitude falls to half value when $p = \pm n_0$,

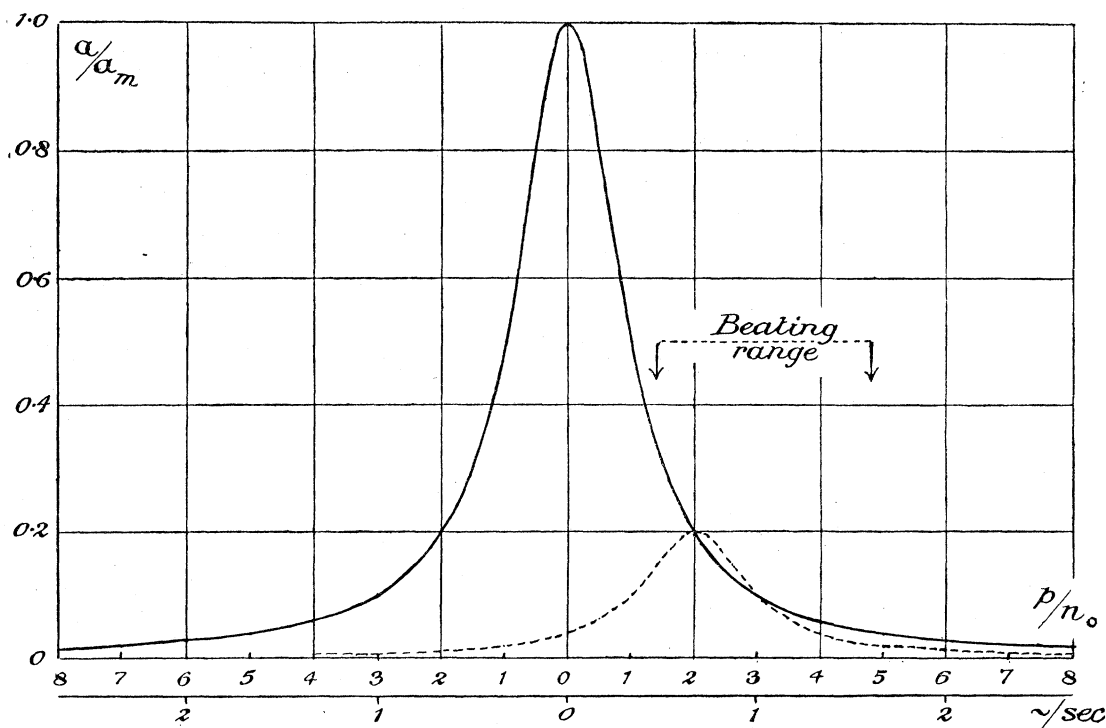

Fig. 15. Response curve.

i.e. when the difference in frequency between interrupter and current is equal to the natural frequency of the galvanometer.

[For the galvanometer with period 3 sec. used in the experiments the half-value amplitude is given for a true frequency of $\frac{1}{3}$ /sec., or the "width of response" is $\frac{2}{3}$ /sec. The true frequency of the forced motion of this galvanometer over the range of the response is indicated on the lower scale in fig. 15.]

Resolving Power.—Consider first the case of two equal components. Let

- a_m = maximum amplitude for each separately,
- q = frequency difference,
- a_1, a_2 = response amplitude, for one component alone, at frequencies $\frac{1}{2}q$ and q respectively from the maximum.

The superposition of the two response curves is shown in fig. 16. The degree of resolution is determined by the ratio

$$\frac{\text{amplitude at central dip}}{\text{amplitude at summit on either side}}$$

Approximately this ratio is $\frac{2a_1}{a_m + a_2}$, neglecting a slight displacement of the maxima.

If we take for the limit of resolution a ratio $5/6$, *i.e.* a drop of 16 per cent. at the centre, this corresponds to the condition $q = 2n_0$. Hence the least difference of frequency resolvable is twice the frequency of the galvanometer. For the experiments this limit is $\frac{2}{3}$ /sec., but practically a rather higher degree of resolution was obtained. Undoubtedly this is due to the fact that the above ratio is that of the maximum amplitudes obtained by taking the two vibrations always in the same phase. If they are taken in opposite phases the two peaks are completely separated, as indicated by the dotted curve in fig. 16. The motion of the galvanometer is in general compounded of

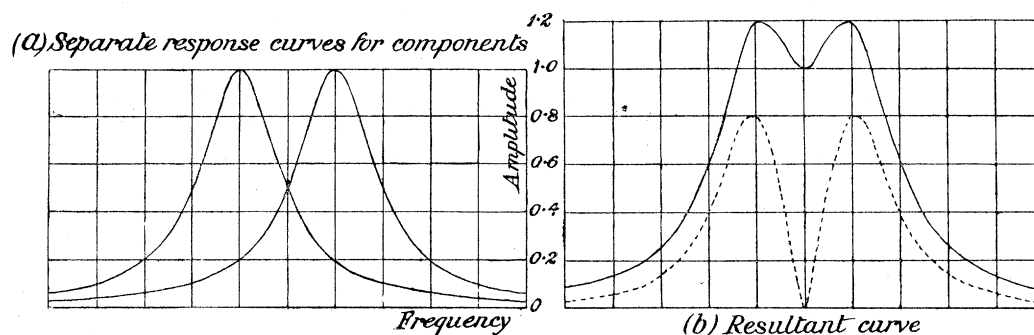

Fig. 16. Resolving power.

two S.H. motions of different amplitude and different frequency, but the maximum excursion is the easiest observed. Midway between, the two components become equal in amplitude and frequency, giving rise to pronounced beating. The beats have a frequency which is variable between the two peaks, but on either side it has the constant value q . For extremely close components (q/n_0 very small) practically the whole response is characterised by beating with frequency q , so that from this point of view the resolving power is unlimited. With components very unequal in magnitude the presence of the companion is generally detected by beating *on one side only* of the response. This will be understood by examination of fig. 15, where the response curve due to a companion of amplitude $\frac{1}{5}$ of the primary is represented by the broken line. The region of most distinct beating is where the two amplitudes approach equality.

Time Required for Analysis.—We shall suppose that the interrupter frequency n is increasing at a uniform rate, $\frac{dn}{dt} = c$, in going through a response due to an isolated component of frequency n_1 . It is required that the value of the maximum deflection shall not possibly be less than a certain fraction, say 90 per cent., of the full response obtained by an infinitely slow rate. Measuring the time t from the instant of synchronism, we may put $n = n_1 + ct$.

If at the instant $t = 0$ the phase difference between current and interrupter happens to be 0, or π , the conditions will be as favourable as possible. It is only necessary for this phase condition to persist practically unchanged for a time interval sufficient for the galvanometer to deflect. For a galvanometer in the dead-beat condition this interval

is approximately $\frac{1}{2}T$, where T is the period when undamped. A phase change of $\pm \frac{\pi}{8}$ may be allowed at either end of the interval, which we may take as extending from $t = -\frac{1}{4}T$ to $t = +\frac{1}{4}T$. Then since $n - n_1$ is the phase change per sec. at t , the required condition is expressed by

$$\frac{\pi}{8} = \int_0^{\frac{1}{4}T} (n - n_1) dt = \int_0^{\frac{1}{4}T} ct dt = \frac{1}{2}c \left(\frac{T}{4}\right)^2,$$

therefore

$$c = \frac{4\pi}{T^2} \text{radian/sec.}$$

Hence the limiting rate is $\frac{2}{T^2}$ /sec. Thus in the experiments, with $T = 3$ sec., unit range 1/sec. can be covered in $4\frac{1}{2}$ sec. But since the phase at synchronism may be unfavourable, the rate must be much slower than the above limit—probably about $\frac{1}{16}$ the rate.

The investigation shows that the limiting rate is the same at all frequencies, and it is inversely as the square of the galvanometer period. The result is of importance in considering the possibilities of making a photographic record of a spectrum by a continuous sweep through the whole range of frequency.